

# Concrete Insert – ZCI

## Concrete Insert

Standard finishes are Electro-Galvanized (EG) and Plain (PL).

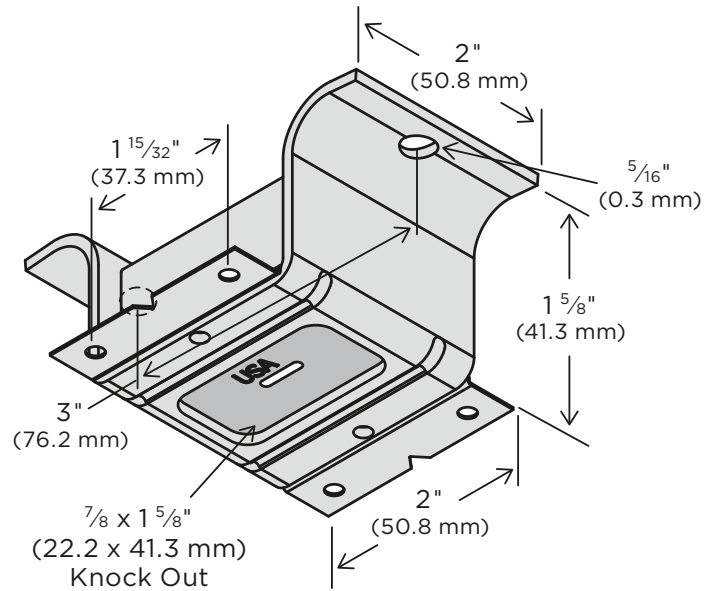

CATALOG NUMBER	WEIGHT		DESIGN LOAD	
	lbs.		lbs.	kN
ZCI0000EG	0.44		600	2.67
ZCI0000PL	0.42		600	2.67

Material is 1 5/8" (41.3 mm) wide x 3/8" (6.3 mm) thick unless specified. Holes are 9/16" (14.3 mm) diameter, 1 3/16" (20.6 mm) center to edge on 1 7/8" (47.6 mm) centers unless specified.

### Material Specifications and Finishes

Carbon Steel – ASTM A1011-00 SS GR 33 or ASTM A1011-00CS Type B

EG – Electro-Galvanized. Electroplating deposits zinc on the surface of the steel by electrolysis from a bath of zinc salts. Recommended for relatively dry indoor use. This is the standard coating for most ZI-Strut products. Thickness of applied zinc is between 0.2 mils and 0.5 mils (5.1 μm to 12.7 μm). Coatings on ZI-Strut EG products meet ASTM B633 SC1 Type III.

PL – Plain. No coating on the steel except some oil left on the part from the pickle and oil or fabrication process.

Note: Specifications subject to change without notice.

## SUBMITTAL INFORMATION

PROJECT: \_\_\_\_\_ CONTRACTOR: \_\_\_\_\_ DATE: \_\_\_\_\_

ENGINEER: \_\_\_\_\_ SPECIFICATION REFERENCE: \_\_\_\_\_ SYSTEM TYPE: \_\_\_\_\_

LOCATIONS: \_\_\_\_\_ COMMENTS: \_\_\_\_\_

WEL-111822