

Beam Clamp – ZBC13

Beam Clamp Anchor Strap

Standard finish is Pre-Galvanized Zinc (PG).

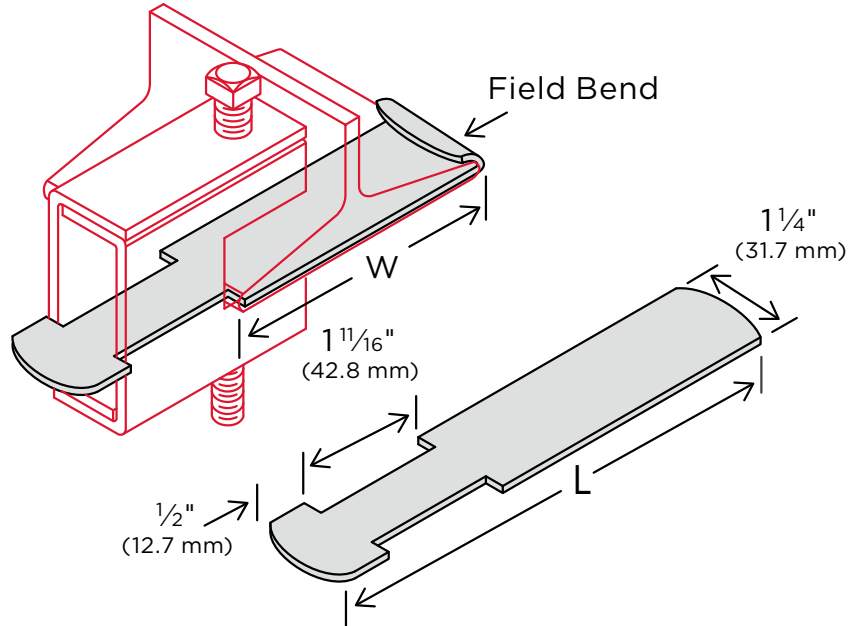

CATALOG NUMBER	WEIGHT		L			W* (MAX)	
	lbs.	in.	mm	in.	mm	in.	mm
ZBC130600PG	0.23	9	228	6	152		
ZBC130900PG	0.30	12	305	9	228		
ZBC131200PG	0.38	15	381	12	305		
ZBC131500PG	0.45	18	457	15	381		

*For beam flange greater than 3/4" (19 mm) thick, use next larger flange width size.

Material Specifications and Finishes

Carbon Steel – ASTM A1011-00 SS GR 33 or ASTM A1011-00CS Type B

PG – ASTM A653 G-90 and G-60 Pre-Galvanized Zinc is produced by continuously rolling steel coils or sheets through molten zinc at the mills. The coils or sheets are slit to size and fabricated by forming, shearing or punching to produce the finished product. During fabrication cut edges are not generally zinc coated; however, the zinc near the uncoated metal becomes a sacrificial anode to protect the bare areas.

Note: Specifications subject to change without notice.

SUBMITTAL INFORMATION

PROJECT: _____ CONTRACTOR: _____ DATE: _____

ENGINEER: _____ SPECIFICATION REFERENCE: _____ SYSTEM TYPE: _____

LOCATIONS: _____ COMMENTS: _____

ZI-112823