

# Beam Clamp – ZRA

## Right Angle Clamp

Standard finish is Hot Dip Galvanized (HD).

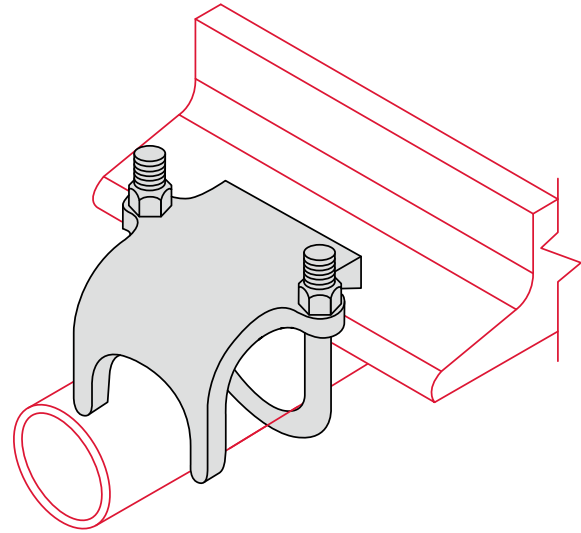

CATALOG NUMBER	WEIGHT	PIPE SIZE	
		lbs.	in.
ZRA0050HD	0.38	½	15
ZRA0075HD	0.41	¾	20
ZRA0100HD	0.46	1	25
ZRA0125HD	0.49	1¼	32
ZRA0150HD	0.59	1½	40
ZRA0200HD	0.88	2	50
ZRA0250HD	1.09	2½	65
ZRA0300HD	1.31	3	80
ZRA0350HD	1.48	3½	90
ZRA0400HD	1.66	4	100

### Material Specifications and Finishes

Carbon Steel – ASTM A1011-00 SS GR 33 or ASTM A1011-00CS Type B

HD – Hot Dip Galvanized After Fabrication. Fabricated product is dipped in molten zinc and is completely covered on all surfaces. Recommended for outdoor use. Coatings on ZI-Strut HD products meet ASTM A123/153. The zinc coating is typically 2.6 mils (66.0 µm) or 1.5 oz. per square foot (0.46 kg per square meter) per side.

Note: Specifications subject to change without notice.

## SUBMITTAL INFORMATION

PROJECT: \_\_\_\_\_ CONTRACTOR: \_\_\_\_\_ DATE: \_\_\_\_\_

ENGINEER: \_\_\_\_\_ SPECIFICATION REFERENCE: \_\_\_\_\_ SYSTEM TYPE: \_\_\_\_\_

LOCATIONS: \_\_\_\_\_ COMMENTS: \_\_\_\_\_

ZI-112823