

Retaining Strap – ZRS

Beam Clamp Retaining Strap

Standard finish is Pre-Galvanized Zinc (PG).

For use with 3/8" and 1/2" rod sizes.

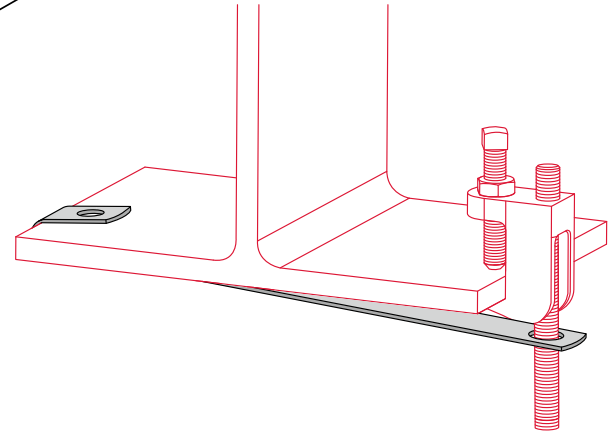
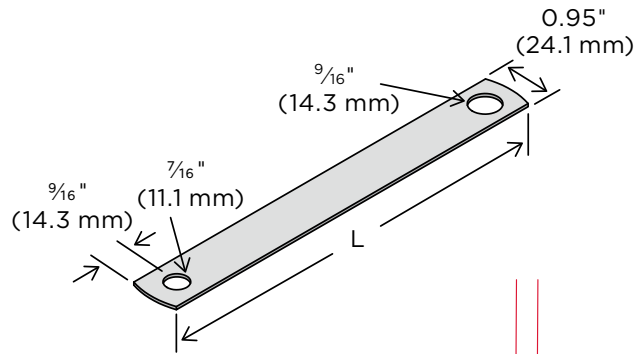

CATALOG NUMBER	GAUGE	BEAM SIZE		LENGTH		WT
		in.	mm	in.	mm	lbs.
ZRS0600PG	16 Gauge (0.054–0.065")	6	152	8	203	0.122
ZRS0800PG		8	203	10	254	0.157
ZRS1000PG		10	254	12	305	0.191
ZRS1200PG		12	305	14	356	0.226
ZRS1400PG		14	356	16	406	0.260

Material Specifications and Finishes

Carbon Steel – ASTM A1011-00 SS GR 33 or ASTM A1011-00CS Type B

Note: Specifications subject to change without notice.

PG – ASTM A653 G-90 Pre-Galvanized Zinc is produced by continuously rolling steel coils or sheets through molten zinc at the mills. The coils or sheets are slit to size and fabricated by forming, shearing or punching to produce the finished product. During fabrication cut edges are not generally zinc coated; however, the zinc near the uncoated metal becomes a sacrificial anode to protect the bare areas.

SUBMITTAL INFORMATION

PROJECT: _____ CONTRACTOR: _____ DATE: _____

ENGINEER: _____ SPECIFICATION REFERENCE: _____ SYSTEM TYPE: _____

LOCATIONS: _____ COMMENTS: _____

ZI-112823