

Electrical – ZEF11

Hinged Fluorescent Fixture Hanger

3 1/4" Channel 9/16" Hole

Standard finish is Electro-Galvanized (EG).

Maximum loading 120 lbs. (0.53 kN).

May be used as a channel hanger.

ZEF46 required for fixture attachment.

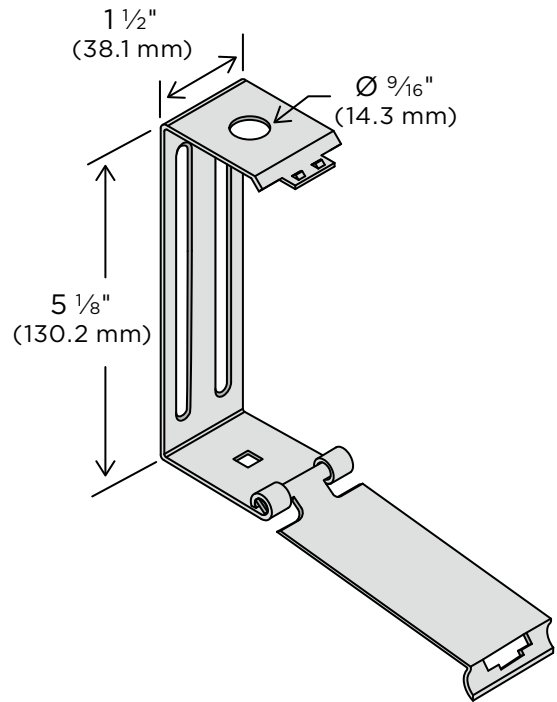

CATALOG NUMBER	WEIGHT
	lbs.
ZEF110000EG	0.44

Material Specifications and Finishes

Carbon Steel – ASTM A1011-00 SS GR 33 or ASTM A1011-00CS Type B

EG – Electro-Galvanized. Electroplating deposits zinc on the surface of the steel by electrolysis from a bath of zinc salts. Recommended for relatively dry indoor use. This is the standard coating for most ZI-Strut products. Thickness of applied zinc is between 0.2 mils and 0.5 mils (5.1 µm to 12.7 µm). Coatings on ZI-Strut EG products meet ASTM B633 SC1 Type III.

Note: Specifications subject to change without notice.

SUBMITTAL INFORMATION

PROJECT: _____ CONTRACTOR: _____ DATE: _____

ENGINEER: _____ SPECIFICATION REFERENCE: _____ SYSTEM TYPE: _____

LOCATIONS: _____ COMMENTS: _____

ZI-113023