

Roller — ZR10

Roller Trolley 2 Bearing Assembly

Standard finish is Electro-Galvanized (EG).

Stainless steel ball bearings (bearings not to be lubricated).

Note: Plate also available in stainless steel.

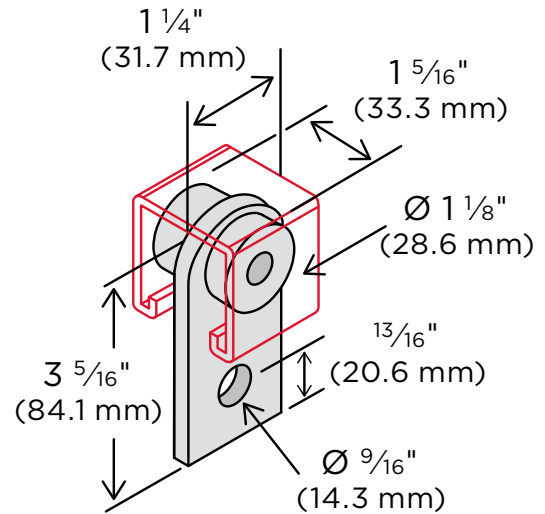

| CATALOG NUMBER | WEIGHT |
|-------------------|--------|
| | lbs. |
| ZR100000EG | 0.46 |

| FPM | RPM | DESIGN LOAD 12 GA. CHANNEL | |
|-----|-----|-------------------------------|------|
| | | lbs. | kN |
| 180 | 600 | 150 | 0.67 |
| 90 | 300 | 225 | 1.00 |
| 30 | 100 | 437 | 1.94 |

Material Specifications and Finishes

Carbon Steel — ASTM A1011-00 SS GR 33 or ASTM A1011-00CS Type B

EG — Electro-Galvanized. Electroplating deposits zinc on the surface of the steel by electrolysis from a bath of zinc salts. Recommended for relatively dry indoor use. This is the standard coating for most ZI-Strut products. Thickness of applied zinc is between 0.2 mils and 0.5 mils (5.1 μm to 12.7 μm). Coatings on ZI-Strut EG products meet ASTM B633 SC1 Type III.

S4 — 304 Stainless Steel — ASTM A240 (Type 304)

Note: Specifications subject to change without notice.

SUBMITTAL INFORMATION

PROJECT: _____ CONTRACTOR: _____ DATE: _____

ENGINEER: _____ SPECIFICATION REFERENCE: _____ SYSTEM TYPE: _____

LOCATIONS: _____ COMMENTS: _____

ZI-120523