

# Roller — ZR11

## Roller Trolley 4 Bearing Assembly

Standard finish is Electro-Galvanized (EG).

Stainless steel ball bearings (bearings not to be lubricated).

Note: Plate also available in stainless steel.

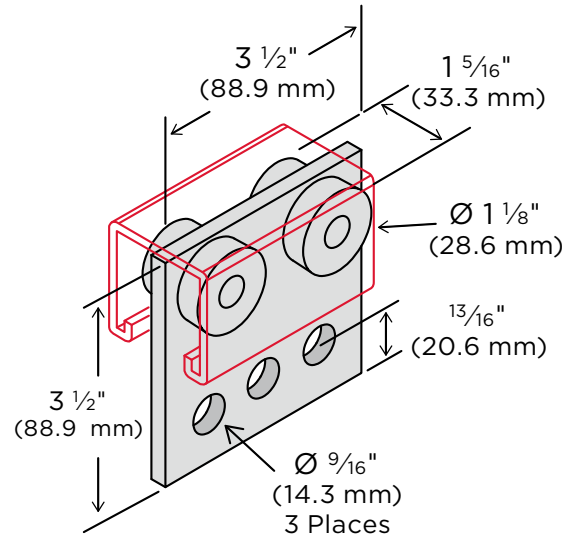

CATALOG NUMBER	WEIGHT
	lbs.
<b>ZR110000EG</b>	1.19

FPM	RPM	DESIGN LOAD 12 GA. CHANNEL	
		lbs.	kN
180	600	300	1.33
90	300	450	2.00
30	100	600	2.67

### Material Specifications and Finishes

Carbon Steel — ASTM A1011-00 SS GR 33 or ASTM A1011-00CS Type B

EG — Electro-Galvanized. Electroplating deposits zinc on the surface of the steel by electrolysis from a bath of zinc salts. Recommended for relatively dry indoor use. This is the standard coating for most ZI-Strut products. Thickness of applied zinc is between 0.2 mils and 0.5 mils (5.1 μm to 12.7 μm). Coatings on ZI-Strut EG products meet ASTM B633 SC1 Type III.

S4 — 304 Stainless Steel — ASTM A240 (Type 304)

Note: Specifications subject to change without notice.

## SUBMITTAL INFORMATION

PROJECT: \_\_\_\_\_ CONTRACTOR: \_\_\_\_\_ DATE: \_\_\_\_\_

ENGINEER: \_\_\_\_\_ SPECIFICATION REFERENCE: \_\_\_\_\_ SYSTEM TYPE: \_\_\_\_\_

LOCATIONS: \_\_\_\_\_ COMMENTS: \_\_\_\_\_

ZI-120523