

Roller — ZR22

Pipe Roller Heavy Duty 6-16" Pipe

Standard finish is Electro-Galvanized (EG).

Max load rating of 1500 lbs. (6.67 kN) with 12 ga. channel.

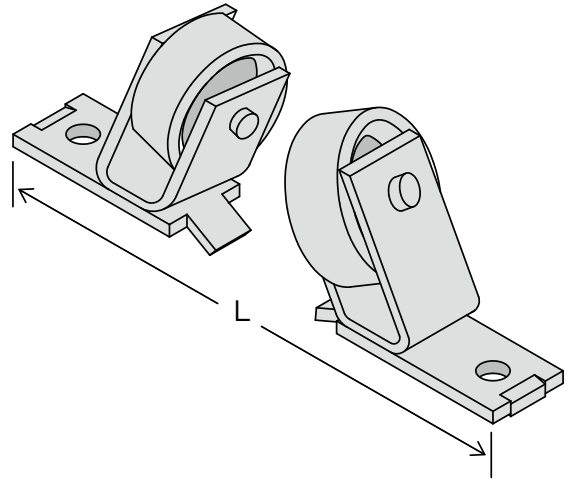

CATALOG NUMBER	WEIGHT
	lbs.
ZR220000EG	8.89

Material Specifications and Finishes

Carbon Steel — ASTM A1011-00 SS GR 33 or ASTM A1011-00CS Type B

EG — Electro-Galvanized. Electroplating deposits zinc on the surface of the steel by electrolysis from a bath of zinc salts. Recommended for relatively dry indoor use. This is the standard coating for most ZI-Strut products. Thickness of applied zinc is between 0.2 mils and 0.5 mils (5.1 µm to 12.7 µm). Coatings on ZI-Strut EG products meet ASTM B633 SC1 Type III.

Note: Specifications subject to change without notice.

SUBMITTAL INFORMATION

PROJECT: _____ CONTRACTOR: _____ DATE: _____

ENGINEER: _____ SPECIFICATION REFERENCE: _____ SYSTEM TYPE: _____

LOCATIONS: _____ COMMENTS: _____

ZI-120523

Roller — ZR22

PIPE SIZE	PIPE COVERING THICKNESS		DIMENSION L		DIMENSION CL	
	in.	mm	in.	mm	in.	mm
6	0	0.0	10 ³ / ₁₆	258.8	6 ⁷ / ₁₆	174.6
	1	25.4	10 ¹ / ₂	266.7	7 ⁷ / ₁₆	200.0
	1½	38.1	10 ¹¹ / ₁₆	271.5	8 ³ / ₁₆	212.7
	2	50.8	10 ¹³ / ₁₆	274.6	8 ⁷ / ₁₆	225.4
	2½	63.5	10 ¹⁵ / ₁₆	277.8	9 ³ / ₁₆	238.1
	3	76.2	11 ³ / ₈	288.9	9 ⁷ / ₁₆	250.8
	4	101.6	11 ⁷ / ₁₆	290.5	10 ¹⁵ / ₁₆	277.8
8	0	0.0	10 ⁷ / ₈	276.2	7 ¹³ / ₁₆	198.4
	1	25.4	11 ³ / ₁₆	284.2	8 ⁷ / ₁₆	225.4
	1½	38.1	11 ³ / ₈	288.9	9 ³ / ₁₆	238.1
	2	50.8	11½	292.1	9 ⁷ / ₁₆	250.8
	2½	63.5	11 ⁵ / ₈	295.3	10 ⁷ / ₁₆	265.1
	3	76.2	12 ¹ / ₁₆	306.4	10 ¹⁵ / ₁₆	277.8
	4	101.6	12 ¹ / ₈	308.0	11 ⁷ / ₁₆	301.6
10	0	0.0	11 ¹⁵ / ₁₆	303.2	8 ¹³ / ₁₆	223.8
	1	25.4	12	304.8	9 ⁷ / ₁₆	250.8
	1½	38.1	11 ¹⁵ / ₁₆	303.2	10 ⁷ / ₁₆	265.1
	2	50.8	10 ³ / ₄	273.1	10 ¹⁵ / ₁₆	277.8
	2½	63.5	12 ⁷ / ₁₆	315.9	11 ³ / ₈	288.9
	3	76.2	12 ⁹ / ₁₆	319.1	11 ⁷ / ₁₆	301.6
	4	101.6	13 ¹ / ₄	336.6	12 ¹³ / ₁₆	325.4
12	0	0.0	12 ⁵ / ₁₆	312.7	9 ³ / ₄	247.7
	1	25.4	11 ⁷ / ₈	301.6	10 ¹⁵ / ₁₆	277.8
	1½	38.1	12 ⁵ / ₁₆	312.7	11 ³ / ₈	288.9
	2	50.8	12 ³ / ₈	314.3	11 ⁷ / ₁₆	301.6
	2½	63.5	13	330.2	12 ⁵ / ₁₆	312.7
	3	76.2	13 ¹ / ₈	333.4	12 ¹³ / ₁₆	325.4
	4	101.6	13 ⁹ / ₁₆	344.5	13 ³ / ₄	349.3
14	0	0.0	12 ¹³ / ₁₆	325.4	10 ⁵ / ₁₆	261.9
	1	25.4	12 ¹⁵ / ₁₆	328.6	11 ³ / ₈	288.9
	1½	38.1	13 ¹ / ₈	333.4	11 ⁷ / ₁₆	301.6
	2	50.8	13 ⁹ / ₁₆	344.5	12 ⁵ / ₁₆	312.7
	2½	63.5	13 ¹⁵ / ₁₆	354.0	12 ¹³ / ₁₆	325.4
	3	76.2	14 ³ / ₈	365.1	13 ¹ / ₄	336.6
	4	101.6	14 ³ / ₄	374.7	14 ¹ / ₄	362.0

