

Strut Clamp – ZCCP

Cushioned Pipe Strut Clamp

Standard finish is Yellow Chromate (YC).

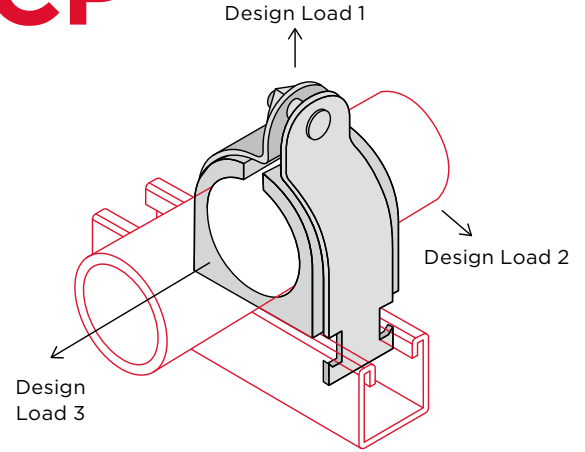

CATALOG NUMBER	PIPE SIZE		PIPE OD		DESIGN LOAD 1		DESIGN LOAD 2		DESIGN LOAD 3		WEIGHT lbs.
	in.	mm	in.	mm	lbs.	kN	lbs.	kN	lbs.	kN	
ZCCP0037YC	3/8	10	0.675	17.1	400	1.78	50	0.22	50	0.22	0.14
ZCCP0050YC	1/2	15	0.840	21.3							0.19
ZCCP0075YC	3/4	20	1.050	26.7	600	2.67	75	0.33	75	0.33	0.23
ZCCP0100YC	1	25	1.315	33.4							0.24
ZCCP0125YC	1 1/4	32	1.660	42.2							0.42
ZCCP0150YC	1 1/2	40	1.900	48.3							0.42
ZCCP0200YC	2	50	2.375	60.3	800	3.56	125	0.56	125	0.56	0.49
ZCCP0250YC	2 1/2	65	2.875	73.0							0.60
ZCCP0300YC	3	80	3.500	88.9							0.77
ZCCP0350YC	3 1/2	90	4.000	101.6							0.93
ZCCP0400YC	4	100	4.500	114.3	1000	4.45	200	0.89	150	0.67	1.10
ZCCP0500YC	5	125	5.562	141.3							1.13

Material Specifications and Finishes

Carbon Steel – ASTM A1011-00 SS GR 33 or ASTM A1011-00CS Type B

YC – Yellow Zinc Dichromate. A 0.5 mil (12.7 µm) electro-galvanized zinc plating meeting ASTM B633 SC1 Type III is applied to the surface of the metal. Yellow Dichromate is applied over the zinc. This results in a yellowish gold appearance and acts as a nonporous barrier sealant that is corrosion resistant and can be painted.

EG – Electro-Galvanized. Electroplating deposits zinc on the surface of the steel by electrolysis from a bath of zinc salts. Recommended for relatively dry indoor use. This is the standard coating for most ZI-Strut products. Thickness of applied zinc is between 0.2 mils and 0.5 mils (5.1 µm to 12.7 µm). Coatings on ZI-Strut EG products meet ASTM B633 SC1 Type III.

S4 – 304 Stainless Steel – ASTM A240 (Type 304)

S6 – 316 Stainless Steel – ASTM A240 (Type 316)

316 Stainless Steel Nuts – ASTM A276-03

Cushion material is a thermoplastic elastomer rated from -65° F to +275° F (-53° C to +135° C).

Note: Specifications subject to change without notice.

SUBMITTAL INFORMATION

PROJECT: _____ CONTRACTOR: _____ DATE: _____

ENGINEER: _____ SPECIFICATION REFERENCE: _____ SYSTEM TYPE: _____

LOCATIONS: _____ COMMENTS: _____

ZI-112823